

Modular LED Luminaire

Zone 2 Ex emb LED Modular Floodlight / Bulkhead Luminaire

Specification:

Main Body:

Marine Grade Aluminium

Diffuser:

Polycarbonate

Gaskets:

Silicone

External Fasteners:

A4 Stainless Steel

Stirrup Bracket:

316 Stainless Steel

T Rating:

T4

Weight:

6.0kg per module



Key Features:

- Modular construction allows the modules to be supplied interlinked with each other to provide greater light output.
- Can be used as a single unit – small floodlight or bulkhead or linked together to replicate a large 250W/400W floodlight.
- Each module utilises 48 off 1.2W LED's
- Integrated power supply.
- Low power consumption.
- Rugged construction – resistant to vibration.
- Independently photometrically tested.
- All units supplied with 2 cable entries as standard. Additional entries available on request.
- IP66 and IP67.
- Emergency version available. See data sheet HDL206E.
- Optional wire guard available for extra protection.
- Narrow, Medium, Wide and Extra Wide beam light output available.

In comparison to typical Ex d floodlights:

- 60% less weight.
- 50% less power consumption.
- One man installation.
- LED technology will give a predicted lamp life of 10 years+.
- No light pollution.
- Instant start and restrike.
- No light degradation at low temperatures.
- Penetrating white light.
- Photocell option available.
- No flamepaths to maintain.
- Low cost of installation, operation and maintenance.

Engineering Solutions
Design to Manufacture

HADAR
LIGHTING 

Hadar Lighting, Jubilee Industrial Estate, Ashington
Northumberland, NE63 8UG United Kingdom

T: +44 (0) 1670 814 877
F: +44 (0) 1670 858 638

enquiries@hadar-lighting.co.uk

www.hadar-lighting.co.uk

Protection:

II 3GD Ex emb IIC T4 Gb IP66/67, Ex t IIIC T103°C Db

Certification: ATEX and ABS certified.

	Certification	Ambient	Voltage Range	Certificate
HDL206S	II 3GD Ex emb IIC T4 Gb IP66/67, Ex t IIIC T103°C Db	-20°C to +50°C	100V to 254V AC input 24V AC/DC	SIRA 11ATEX4314X ABS 11-LD801943-PDA

Electrical Specifications:

Electrical Specification			
Lamp Options	Power consumption	Power factor	Available power supplies
24 x 1.2W LED's	30W Max	0.95	100V – 254V 47/63Hz AC only or 24V AC/DC
48 x 1.2W LED's	60W Max		
96 x 1.2W LED's	120W Max		
144 x 1.2W LED's	180W Max		

Installation:

Terminals: Up to 4mm² terminals for live, neutral, earth and looping are provided. Internal and external earth as standard.
Cable Entries: 2 x M20, one fitted with approved stopper plug, other entries available on request.
Suspension: Via stirrup bracket, other mounting accessories available. Stainless steel eyebolt for safety chain included as standard.
Installation: Installation document supplied.

Ordering Matrix:

Field	Options
Product	HDL206S
Version (LEDs)	0 – 24 LEDs 1 – 48 LEDs 2 – 96 LEDs 3 – 144 LEDs
Voltage	H – 100 - 254V AC only L – 24V AC/DC
Beam Pattern	N – Narrow M – Medium W – Wide X – Extra wide
Mount	H – Horizontal mount (single module version only) V – Vertical mount C – Ceiling mount
Light	W – White light R – Infra red light Y – Yellow light Other colours available on request
Cable Entries	0 – M20 5 – M25
Other Options	04 – Colour RAL 7035 (Grey) 09 – Colour RAL 7035 (Grey) c/w Photocell

Dimensions:

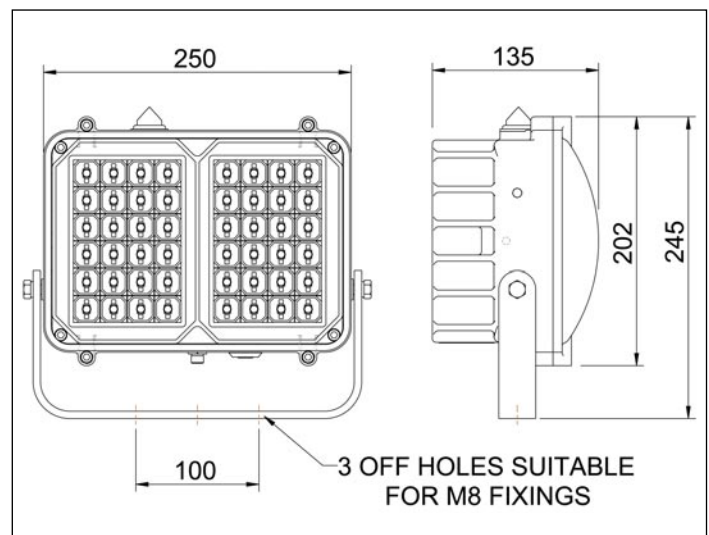

Weight:
 24 and 48 LED Luminaire: 6kg
 96 LED Luminaire: 12kg
 144 LED Luminaire: 18kg

Notes:
 1) Typical ordering reference HDL206S1HMHW004.
 2) Photometric Data available from the website or contact sales office.



Horizontal mount



Vertical mount